

## Sample Question Paper 2020-21

### General Instructions:

1. This question paper contains two parts A and B.
2. Both Part A and Part B have internal choices.

#### Part – A:

1. It consists of two sections- I and II
2. Section I has 16 questions. Internal choice is provided in 5 questions.
3. Section II has four case study-based questions. Each case study has 5 case-based sub-parts. An examinee is to attempt any 4 out of 5 sub-parts.

#### Part – B:

1. Question No 21 to 26 are Very short answer Type questions of 2 mark each,
2. Question No 27 to 33 are Short Answer Type questions of 3 marks each
3. Question No 34 to 36 are Long Answer Type questions of 5 marks each.
4. Internal choice is provided in 2 questions of 2 marks, 2 questions of 3 marks and 1 question of 5 marks.

## PART-A

### Section-I

1. O is the centre of a circle of radius 8 cm. The tangent at a point A on the circle cuts a line through O at B such that  $AB = 15$  cm. Find OB.



2. Given that HCF (96,404) is 4, find the LCM (96,404).

**OR**

State the fundamental Theorem of Arithmetic.

3. The mean of first 'n' odd natural numbers is  $\frac{n^2}{81}$ . Then n =  
A. 9                      B. 81                      C. 27                      D. 18
4. The centroid of the triangle whose vertices (1, 4), (-1, -1), (3, -2) is.  
A.  $(\frac{7}{3}, 1)$               B.  $(1, \frac{1}{3})$               C. (3, 1)              D.  $(\frac{3}{2}, \frac{1}{2})$
5. The value of  $2\tan^2 45^\circ + \cos^2 30^\circ + \sin^2 60^\circ$  is  
A.  $\frac{5}{2}$                       B. 2                      C.  $\frac{3}{2}$                       D. 4
6. A bag contains 3 red balls and 5 black balls. A ball is drawn at random from the bag. What is the probability that the ball drawn is red?

**OR**

A die is thrown once. What is the probability of getting a prime number?

7. A ladder 15 m long just reaches the top of a vertical wall. If the ladder makes an angle of  $60^\circ$  with the wall, then the height of the wall is  
A.  $15\sqrt{3}$  meters    B.  $\frac{15\sqrt{3}}{2}$  meters    C.  $\frac{15}{2}$  meters    D. 15 meters
8. In the given fig.  $DE \parallel BC$ ,  $\angle ADE = 70^\circ$  and  $\angle BAC = 50^\circ$ , then  $\angle BCA =$   
\_\_\_\_\_

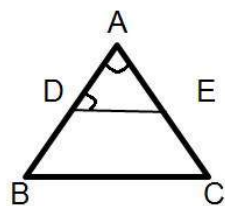

**OR**

In the given figure,  $AD = 2\text{ cm}$ ,  $BD = 3\text{ cm}$ ,  $AE = 3.5\text{ cm}$  and  $AC = 7\text{ cm}$ . Is  $DE$  parallel to  $BC$  ?

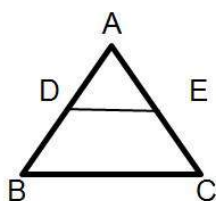

9. If the  $n$ th term of AP  $-2, 5, 12, \dots$  is 89, then value of  $n$  is  
 A. 12                      B. 14                      C. 11                      D. 13
10. For what values of  $p$  does the pair of equations  $4x + py + 8 = 0$  and  $2x + 2y + 2 = 0$  has unique solution?

**OR**

What type of straight lines will be represented by the system of equations  $2x + 3y = 5$  and  $4x + 6y = 7$ ?

11. A sequence is defined by  $a_n = \frac{n+1}{n^3} + \frac{1}{n}$ . The value of  $a_1 - a_3$  is \_\_\_\_\_.
12. A hemispherical depression is taken out from a cube with the side ' $2a$ '. The total surface area of the solid is \_\_\_\_\_.

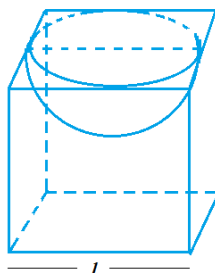

13. If one root of the quadratic equation  $3x^2 - ax + 4 = 0$  is 4. Find the value of  $a$ .
14. Find the area of a sector of a circle with radius 6cm if angle of the sector is  $60^\circ$ .  
 (Take  $\pi = 22/7$ )

**OR**

A horse tied to a pole with 28m long rope. Find the perimeter of the field where the horse can graze. (Take  $\pi = 22/7$ )

15. The value of  $\tan 1^\circ \tan 2^\circ \tan 3^\circ \dots \tan 89^\circ$  is \_\_\_\_\_.
16. What is the common difference of an A.P. in which  $a_{21} - a_7 = 84$ ?



## Section-II

Case study-based questions are compulsory. Attempt any 4 sub parts from each question. Each question carries 1 mark

17. Floor of a room is of dimensions  $5\text{ m} \times 4\text{ m}$  and it is covered with circular tiles of diameters  $50\text{ cm}$  each as shown in given figure.

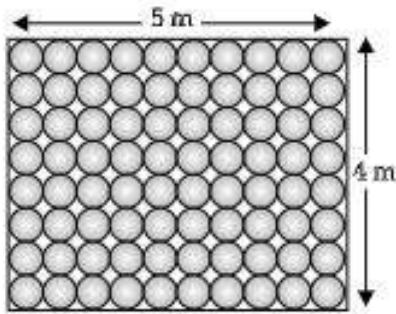

- (i) Find the radius of each circular tile having diameters  $50\text{ cm}$ .
- (a)  $1\text{ m}$
  - (b)  $0.75\text{ m}$
  - (c)  $0.50\text{ m}$
  - (d)  $0.25\text{ m}$
- (ii) Find the area of rectangle having dimensions  $5\text{ m} \times 4\text{ m}$ .
- (a)  $17.5\text{ m}^2$
  - (b)  $15\text{ m}^2$
  - (c)  $21\text{ m}^2$
  - (d)  $20\text{ m}^2$
- (iii) Find the area of each circular tiles.
- (a)  $0.15\text{ m}^2$
  - (b)  $0.251\text{ m}^2$
  - (c)  $0.196\text{ m}^2$
  - (d)  $1.80\text{ m}^2$
- (iv) Find the area of floor that remains uncovered with tiles
- (a)  $4.32\text{ m}^2$
  - (b)  $1.85\text{ m}^2$
  - (c)  $3.73\text{ m}^2$
  - (d)  $2.87\text{ m}^2$

- (v) A line segment joining the centre and a point on the circle is called its .....
- diameter
  - radius
  - chord
  - arc

18. A straight highway leads to the foot of tower. A man standing at the top of the tower observes a car at an angle of depression of  $30^\circ$ , which approaching the foot of the tower with a uniform speed. Six seconds later; the angle of depression of the car is found to be  $60^\circ$ .

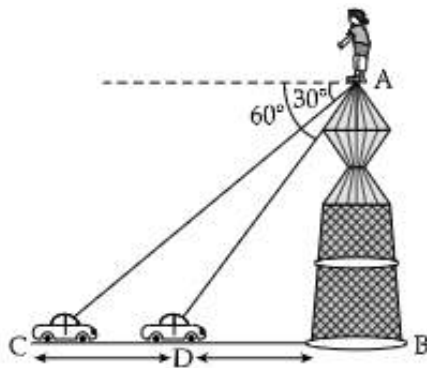

- Find the time taken by the car to reach the foot of the tower from point D to B.
  - 2 sec
  - 3 sec
  - 6 sec
  - 4 sec
- Write the value of  $\csc 30^\circ$ .
  - $2/\sqrt{3}$
  - $\sqrt{3}/2$
  - $1/\sqrt{3}$
  - $\sqrt{3}$
- Write the value of  $\csc 60^\circ$ .
  - $\sqrt{3}$
  - $2/\sqrt{3}$
  - $\sqrt{3}/2$
  - $1/\sqrt{3}$

- (iv) The line drawn from the eye of an observer to the point in the object viewed by the observer.
- Horizontal line
  - Vertical line
  - Line of sight
  - Parallel lines
- (v) If the two lines are parallel; then the alternate opposite angles are .....
- different
  - equal
  - opposite
  - None of these

19. In a potato race, a bucket is placed at the starting point, which is 5 m from the first potato and the other potatoes are placed 3 m apart in a straight line. There are ten potatoes in the line (as shown in figure)

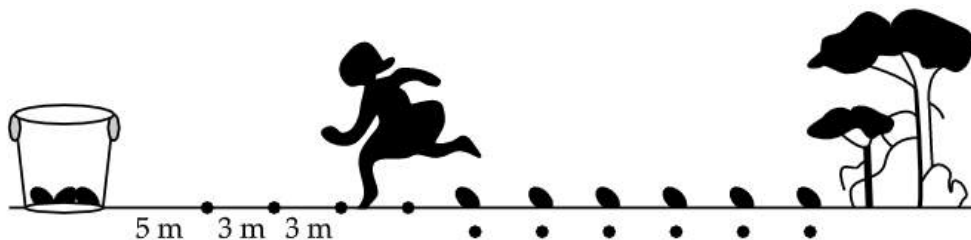

A competitor starts from the bucket, picks up the nearest potato, runs back with it, drops it in the bucket, runs back to pick up the next potato, runs to the bucket to drop it in, and she continues in the same way until all the potatoes are dropped in the bucket.

- What is distance run to pick up the 1<sup>st</sup> potato?
  - 8 m
  - 10 m
  - 12 m
  - 9 m
- What is the distance run to pick up the 2<sup>nd</sup> potato?
  - 12 m
  - 15 m
  - 16 m

- (d) 14 m
- (iii) What is the distance run to pick up the 3<sup>rd</sup> potato?
- (a) 22 m  
 (b) 18 m  
 (c) 21 m  
 (d) 15 m
- (iv) What is the distance run to pick up the 4<sup>th</sup> potato?
- (a) 26 m  
 (b) 30 m  
 (c) 25 m  
 (d) 28 m
- (v) What is the total distance run by the competitor?
- (a) 370 m  
 (b) 350 m  
 (c) 355 m  
 (d) 375 m

20. An aeroplane leaves an airport and flies to north at a speed of 1000 km/hr. At the same time, another aeroplane leaves the same airport and flies to west at a speed of 1200 km/hr.

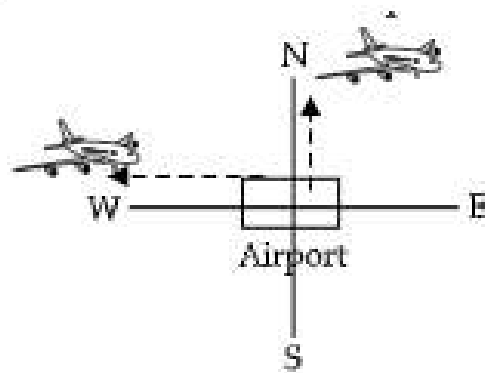

- (i) Find the distance covered by first plane in the north direction after  $1\frac{1}{2}$  hours?
- (a) 1500 km  
 (b) 1600 km  
 (c) 1400 km

- (d) 1300 km
- (ii) Find the distance covered by second plane in the west direction after  $1\frac{1}{2}$  hours
- (a) 1700 km  
 (b) 1800 km  
 (c) 1900 km  
 (d) 2000 km
- (iii) How far apart will be the two planes after  $1\frac{1}{2}$  hours?
- (a)  $300\sqrt{59}$  km  
 (b)  $300\sqrt{63}$  km  
 (c)  $300\sqrt{61}$  km  
 (d)  $300\sqrt{65}$  km
- (iv) The triangle having an angle of measure  $90^\circ$  is called ..... angle triangle.
- (a) Right  
 (b) obtuse  
 (c) acute  
 (d) None of these
- (v) If a line is drawn parallel to one side of a triangle to intersect the other two sides indistinct points; the other two sides are divided in the same ratio. This theorem is known as:
- (a) Basic Proportionality  
 (b) Converse of Thales theorem  
 (c) Pythagoras theorem  
 (d) Similarity of triangles

### PART – B

**All questions are compulsory. In case of internal choices, attempt anyone.**

21. Calculate the perimeter of a triangle with vertices (0, 4), (0, 0) and (3, 0) is

**OR**

The point which divides the line segment joining the points (7, - 6) and (3, 4) in ratio 1:2 internally lies in which quadrant?





22. The first term of an A.P. is 5, the last term is 45 and the sum of all its terms is 400. Find the number of terms and the common difference of the A.P.
23. If radii of two concentric circles are 4 cm and 5 cm, then find the length of each chord of one circle which is tangent to the other circle.
24. Divide a line segment of length 9 cm internally in the ratio 4 : 3.
25. If  $\sin A = \frac{1}{2}$ , then the value of  $\cot A$  ?
26. Find the 21<sup>st</sup> term of an AP whose first two terms are - 3 and 4.

### Part- B

**All questions are compulsory. In case of internal choices, attempt anyone.**

27. Prove that  $\sqrt{3}$  is an irrational number.
28. In the figure shown below, the sides AB, BC and CA of a triangle ABC touch a circle with centre O and radius 'r' at P, Q and R respectively. Prove that:
- (i)  $AB + CQ = AC + BQ$
- (ii)  $\text{Area}(\Delta ABC) = \frac{1}{2} (\text{Perimeter of } \Delta ABC) \times r$

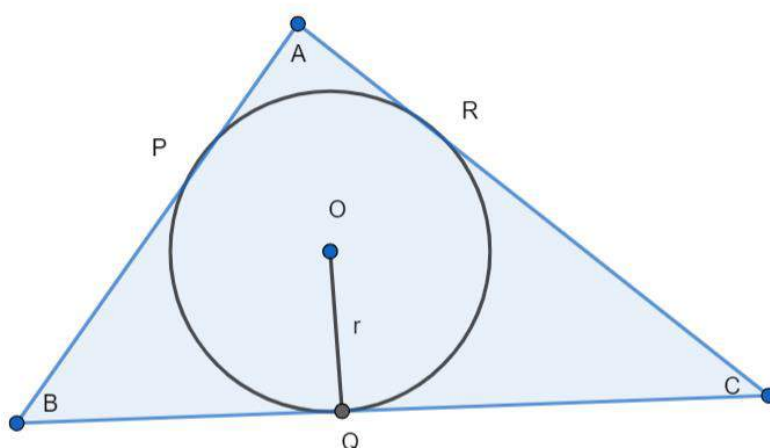

29. Five years hence, the age of Anjali will be three times that of Dimple. Five years ago, Anjali's age was seven times that of Dimple. What are their present ages?



30. A bag contains some red balls, some blue balls and some white balls. Out of which the number of blue balls is twice the number of white balls, and the probability of drawing a red ball is  $\frac{1}{2}$ . Find the probability of drawing a white ball.

**OR**

All queens, aces and kings are removed from a pack of 52 cards. The remaining cards are well-shuffled, and then a card is drawn from it. Find the probability that the card is

- (i) A black card      (ii) A red card      (iii) A red face card

31. A solid is in the form of a cylinder with hemispherical ends. The total height of the solid is 19 cm, and the diameter of the cylinder is 7 cm. Find the volume and total surface area of the solid. (Use  $\pi = \frac{22}{7}$ ).

32. Prove that:  $\frac{\tan x + \sec x - 1}{\tan x - \sec x + 1} = \frac{1 + \sin x}{\cos x}$

33. A square is inscribed in a quadrant of a circle whose radius is 28cm as shown in the figure below. Find the area of the shaded region.

$\left[ \text{Take } \pi = \frac{22}{7} \right]$

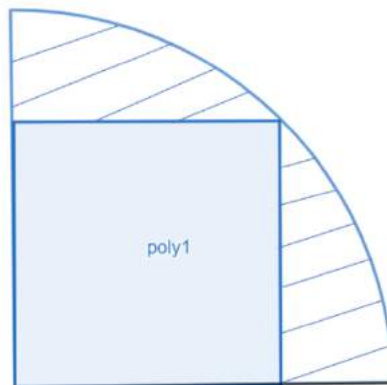

**OR**

The length of the minute hand of a clock is 10cm. Find the area swept by the minute hand of a clock from the time 6:10 AM to 7:05 AM.

### PART – B

**All questions are compulsory. In case of internal choices, attempt anyone.**

34. From a point 200m above the lake, the angle of elevation of a stationary helicopter is  $30^\circ$ , and the angle of depression of reflection of the helicopter in the lake is  $45^\circ$ . Find the height of the helicopter.

**OR**

If the angles of elevation of a tower from two points at distances  $a$  and  $b$ , where  $a > b$  from its foot and in the same straight line from it are  $30^\circ$  and  $60^\circ$  respectively, the find the value of  $\sqrt{\frac{a}{b}}$ .

35. If the  $p$ th term of an A.P. is  $q$  and the  $q$ th term is  $p$ , prove that its  $n$ th term is  $(p + q - n)$ .
36. Find the value of  $p$  for the following distribution whose mean is 14.

<b>x:</b>	5	10	12	<b>p</b>	16	18	20
<b>f :</b>	10	20	15	20	12	8	4

.....

## PART-A

## Section-I

1. **Solution:**

$$OB^2 = 8^2 + 15^2$$

$$OB = \sqrt{64 + 225}$$

$$OB = 17 \text{ cm}$$

2. **Solution:**

HCF X LCM = product of two numbers

$$\text{LCM}(96, 404) = \frac{96 \times 404}{\text{HCF}(96, 404)} = \frac{96 \times 404}{4}$$

$$\text{LCM} = 9696$$

**OR**

State the fundamental Theorem of Arithmetic.

**Solution:** Every composite number can be expressed (factorized) as a product of primes, and this factorization is unique, apart from the order in which the factors occur.

3. **Solution:** First 'n' odd natural numbers are

1, 3, 5, ..., (n terms)

This is an AP with

First term,  $a = 1$ Common difference,  $d = 2$ 

$$\therefore \text{Sum of first 'n' terms} = \frac{n}{2} [2a + (n-1)d]$$

$$\Rightarrow S_n = \frac{n}{2} [2 + (n-1)2]$$

$$\Rightarrow S_n = \frac{n}{2} [2 + 2n - 2]$$

$$\Rightarrow S_n = n^2$$

$$\text{Mean of first 'n' odd natural numbers} = \frac{1+3+\dots}{n}$$



$$\Rightarrow \frac{n^2}{n} = \frac{n^2}{81}$$

$$\Rightarrow n = 81$$

Hence, Option B is correct.

4. **Solution:** We know that centroid of a triangle for  $(x_1, y_1)$ ,  $(x_2, y_2)$  and  $(x_3, y_3)$  is

$$G(x, y) = \left( \frac{x_1 + x_2 + x_3}{3}, \frac{y_1 + y_2 + y_3}{3} \right)$$

∴ For coordinates  $(1, 4)$ ,  $(-1, -1)$ ,  $(3, -2)$ ,

$$\text{Centroid of triangle} = \left( \frac{1-1+3}{3}, \frac{4-1-2}{3} \right)$$

$$= \left( 1, \frac{1}{3} \right)$$

Hence, centroid of triangle is  $\left( 1, \frac{1}{3} \right)$

5. **Solution:**  $2\tan^2 45^\circ + \cos^2 30^\circ + \sin^2 60^\circ$

$$= 2(1)^2 + \left( \frac{\sqrt{3}}{2} \right)^2 + \left( \frac{1}{2} \right)^2$$

$$= 2 + \frac{3}{4} + \frac{1}{4} = 4$$

Hence, Option D is correct.

6. **Solution:** No. of red balls = 3, No. black balls = 5

Total number of balls = 5 + 3 = 8

$$\text{Probability of red balls} = \frac{3}{8}$$

**OR**

A die is thrown once. What is the probability of getting a prime number?

7. **Solution:**

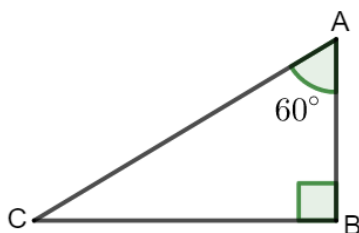

Let AB and AC be the ladder and wall respectively.

Given, ladder makes an angle of  $60^\circ$  with wall

$$\angle A = 60^\circ$$

Also, length of ladder, AC = 15 m

To find: height of wall i.e. AB

We have,

$$\cos A = \frac{\text{Base}}{\text{Hypotenuse}} = \frac{AB}{AC}$$

$$\Rightarrow \cos 60^\circ = \frac{AB}{15}$$

$$\Rightarrow AB = 15 \times \frac{1}{2} = \frac{15}{2} \text{ meters}$$

Hence, Option C is correct.

8. **Solution:** By converse of Thale's theorem DE || BC

$$\angle ADE = \angle ABC = 70^\circ$$

$$\text{Given } \angle BAC = 50^\circ$$

$$\angle ABC + \angle BAC + \angle BCA = 180^\circ \text{ (Angle sum property of triangles)}$$

$$70^\circ + 50^\circ + \angle BCA = 180^\circ$$

$$\angle BCA = 180^\circ - 120^\circ = 60^\circ$$

**OR**

**Solution:**

$$EC = AC - AE = (7 - 3.5) \text{ cm} = 3.5 \text{ cm}$$

$$\frac{AD}{BD} = \frac{2}{3} \text{ and } \frac{AE}{EC} = \frac{3.5}{3.5} = 1$$

$$\text{So, } \frac{AD}{BD} \neq \frac{AE}{EC}$$

Hence, by converse of Thale's Theorem, DE is not Parallel to BC.

9. **Solution:** We know that, nth term of an AP is

$$a_n = a + (n - 1)d, \text{ where}$$

a = first term and d = common difference

Here,

$$\text{First term, } a = -2$$

$$\text{Common difference, } d = a_2 - a_1 = 5 - (-2) = 7$$

$$\text{nth term, } a_n = 89$$

To find: n

Putting values, we get

$$\Rightarrow 89 = -2 + (n - 1)7$$

$$\Rightarrow 91 = (n - 1)7$$

$$\Rightarrow n - 1 = 13$$

$$\Rightarrow n = 14$$

Hence, Option B is correct.

10. **Solution:**  $\frac{a_1}{a_2} \neq \frac{b_1}{b_2}$  is the condition for the given pair of equations to have unique solution.

$$\frac{4}{2} \neq \frac{p}{2}$$

$$p \neq 4$$

Therefore, for all real values of  $p$  except 4, the given pair of equations will have a unique solution.

**OR**

**Solution:**

$$\text{Here, } \frac{a_1}{a_2} = \frac{2}{4} = \frac{1}{2}$$

$$\frac{b_1}{b_2} = \frac{3}{6} = \frac{1}{2} \text{ and } \frac{c_1}{c_2} = \frac{5}{7}$$

$$\frac{1}{2} = \frac{1}{2} \neq \frac{5}{7}$$

$\frac{a_1}{a_2} = \frac{b_1}{b_2} \neq \frac{c_1}{c_2}$  is the condition for which the given system of equations

will represent parallel lines.

So, the given system of linear equations will represent a pair of parallel lines.

**11. Solution: Given:**  $a_n = \frac{n+1}{n^3} + \frac{1}{n}$

$$a_1 = \frac{1+1}{1^3} + \frac{1}{1}$$

$$a_1 = \frac{2}{1} + 1 = 3$$

$$a_1 = 3$$

$$a_3 = \frac{3+1}{3^3} + \frac{1}{3}$$

$$a_3 = \frac{4}{27} + \frac{1}{3}$$

$$a_3 = \frac{13}{27}$$

Therefore,

$$a_1 - a_3 = 3 - \frac{13}{27} = \frac{81-13}{27}$$

$$a_1 - a_3 = \frac{68}{27}$$

**12. Solution:** Total Surface Area = TSA of cube - Area of hemisphere base + CSA of Hemisphere

$$\Rightarrow 6(2a)^2 - \pi r^2 + 2\pi r^2 \quad [1]$$

Here, diameter of hemisphere = side of cube =  $2a$

$\Rightarrow$  radius of hemisphere =  $\frac{1}{2} \times$  diameter = ' $a$ '

Simplifying equation [1] and putting  $r = 'a'$ , we have

$$\Rightarrow \text{Total Surface Area} = 24a^2 + \pi a^2$$



**13. Solution:** The root of an equation must satisfy the equation.

∴ If 4 is a root of the given equation, then,

$$3(4)^2 - 4a + 4 = 0$$

$$48 - 4a + 4 = 0$$

$$-4a + 52 = 0 \Rightarrow -4a = -52$$

$$a = \frac{52}{4}$$

$$a = 13$$

**Hence, the value of a is 13.**

**14. Solution:**  $\theta = 60^\circ$

$$\text{Area of sector} = \frac{\theta}{360^\circ} \Pi r^2$$

$$A = \frac{60^\circ}{360^\circ} \times \frac{22}{7} \times (6)^2 \text{ cm}^2$$

$$A = \frac{1}{6} \times \frac{22}{7} \times 36 \text{ cm}^2$$

$$A = 60^\circ 360^\circ \times 227 \times (6)^2 \text{ cm}^2$$

$$A = 16 \times 227 \times 36 \text{ cm}^2 \\ = 18.86 \text{ cm}^2$$

**OR**

**Solution:**

Horse can graze in the field which is a circle of radius 28 cm.

$$\text{So, required perimeter} = 2\Pi r = 2.\Pi(28) \text{ cm}$$

$$= 2 \times 227 \times (28) \text{ cm} = 176 \text{ cm}$$

**15. Solution:** We know that,  $\tan(90 - \theta) = \cot \theta$  and

$$\tan \theta \cot \theta = 1 \left[ \because \tan \theta = \frac{1}{\cot \theta} \right]$$

$$\Rightarrow \tan 1^\circ \tan 2^\circ \tan 3^\circ \dots \tan 87^\circ \tan 88^\circ \tan 90^\circ$$

$$\Rightarrow \tan 1^\circ \tan 2^\circ \tan 3^\circ \dots \cot 3^\circ \cot 2^\circ \cot 1^\circ$$

$$\Rightarrow \tan 1^\circ \cot 1^\circ \tan 2^\circ \cot 2^\circ \tan 3^\circ \cot 3^\circ \dots \tan 44^\circ \cot 44^\circ \tan 45^\circ$$

$$\Rightarrow 1 \times 1 \times 1 \times \dots \times 1 \times 1 = 1 \left[ \because \tan 45^\circ = 1 \right]$$

Hence, Option A is correct.

**16. Solution:** Common difference = 6



## Section-II

17. (i) Answer: 0.25 m  
(ii) Answer: 20 m<sup>2</sup>  
(iii) Answer: 0.196 m<sup>2</sup>  
(iv) Answer: 4.32 m<sup>2</sup>  
(v) Answer: Radius
18. (i) Answer: 3 sec  
(ii) Answer:  $2/\sqrt{3}$   
(iii) Answer:  $2/\sqrt{3}$   
(iv) Answer: Line of sight  
(v) Answer: Equal
19. (i) Answer: 10 m  
(ii) Answer: 16 m  
(iii) Answer: 22 m  
(iv) Answer: 28 m  
(v) Answer: 370 m
20. (i) Answer: 1500 km  
(ii) Answer: 1800 km  
(iii) Answer:  $300\sqrt{61}$  Km  
(iv) Answer: Right angled triangle  
(v) Answer: Basic Proportionality Theorem

## PART – B

21. **Solution:** We plot the vertices of a triangle i.e., (0, 4), (0, 0) and (3, 0) on the paper shown as given below



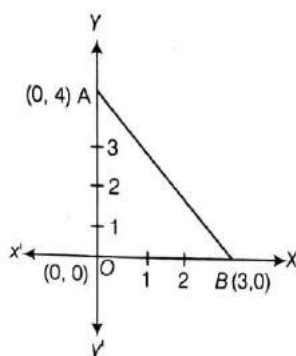

Now, perimeter of  $\triangle AOB$  = Sum of the length of all its sides:  
 $= d(AO) + d(OB) + d(AB)$

$\therefore$  Distance between the points  $(x_1, y_1)$  and  $(x_2, y_2)$ ,

$$d = \sqrt{(x_2 - x_1)^2 + (y_2 - y_1)^2}$$

= Distance between A(0, 4) and O(0, 0) + Distance between O(0, 0) and B(3, 0)

+ Distance between A(0, 4) and B(3, 0)

$$= \sqrt{(0-0)^2 + (0-4)^2} + \sqrt{(3-0)^2 + (0-0)^2}$$

$$+ \sqrt{(3-0)^2 + (0-4)^2}$$

$$= \sqrt{0+16} + \sqrt{9+0} + \sqrt{(3)^2 + (4)^2}$$

$$= 4 + 3 + \sqrt{9+16}$$

$$= 7 + \sqrt{25} = 7 + 5 = 12$$

Hence, the required perimeter of triangle is 12.

OR

### Solution:

Let's take A and B the joining point and P is the dividing point;

Let's assume the co - ordinates of point P = x and y

By using Section formula;

x co - ordinate of point P will be -

$$x = \frac{mx_2 + nx_1}{m+n} \text{ and}$$

y co - ordinate of point P will be -

$$y = \frac{my_2 + ny_1}{m+n}$$

$$\therefore x = \frac{1(3) + 2(7)}{1+2}$$

$$y = \frac{1(4) + 2(-6)}{1+2}$$

Given that,

$$x_1 = 7, y_1 = -6,$$

$$x_2 = 3, y_2 = 4$$

$$m = 1 \text{ and}$$

$$n = 2$$

$$x = \frac{3+14}{3} = \frac{17}{3}$$

$$y = \frac{4-12}{3} = -\frac{8}{3}$$

So,  $(x, y) = \left(\frac{17}{3}, -\frac{8}{3}\right)$  lies in IV quadrant.

[Since, in IV quadrant, x - coordinate is positive and y - coordinate is negative]

22. **Solution:**  $a = 5, a_n = 45$

$$\frac{n}{2}[5 + 45] = 400$$

$$n = 16$$

$$\text{Also, } a + (n - 1)d = 45$$

$$5 + (16 - 1)d = 45$$

$$15d = 40$$

$$d = \frac{8}{3}$$

23. **Solution:** Given: Two circles (say C1 and C2) with common center as O and

Radius of circle C1,  $r_1 = 4$  cm

Radius of circle C2,  $r_2 = 5$  cm

Also say AC is the chord of circle C2 which is tangent to circle C1 and OB is the radius of circle to the point of contact of tangent AC .

To find : Length of chord AC

Now, Clearly  $OB \perp AC$  [ As tangent to at any point on the circle is perpendicular to the radius through point of contact]

So OBC is a right-angled triangle

So, it will satisfy Pythagoras theorem [ i.e.  $(\text{base})^2 + (\text{perpendicular})^2 = (\text{hypotenuse})^2$  ]

i.e.

$$(OB)^2 + (BC)^2 = (OC)^2$$

As OB and OC are the radii of circle C1 and C2 respectively.

So

$$(4)^2 + (BC)^2 = (5)^2$$

$$16 + (BC)^2 = 25$$

$$(BC)^2 = 25 - 16 = 9$$

$$BC = 3 \text{ cm}$$

Also



$AB = BC$  [ Perpendicular through the center to a chord in a circle (C2 in this case) bisects the chord]

And

$$AC = AB + BC$$

$$= AB + AB = 2AB = 2(3) = 6 \text{ cm}$$

24. **Solution:** We need to divide this line segment  $AB$  of length 9 cm internally in the ratio 4 : 3.

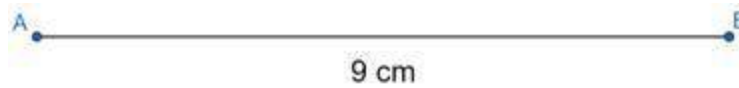

Step 1: Draw a line segment  $AC$  of arbitrary length and at an any angle to  $AB$  such that  $\angle CAB$  is acute.

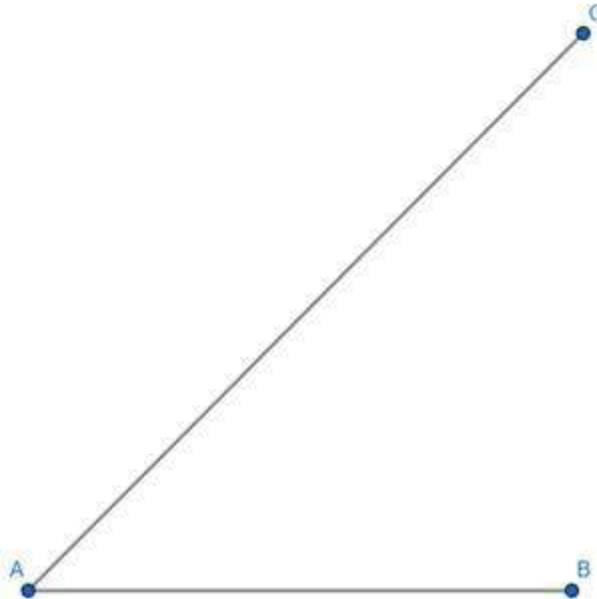

Step 2: We plot  $(4 + 3 =)$  7 points  $A_1, A_2, A_3, A_4, A_5, A_6,$  and  $A_7$  such that  $AA_1 = A_1A_2 = A_2A_3 = A_3A_4 = A_4A_5 = A_5A_6 = A_6A_7$

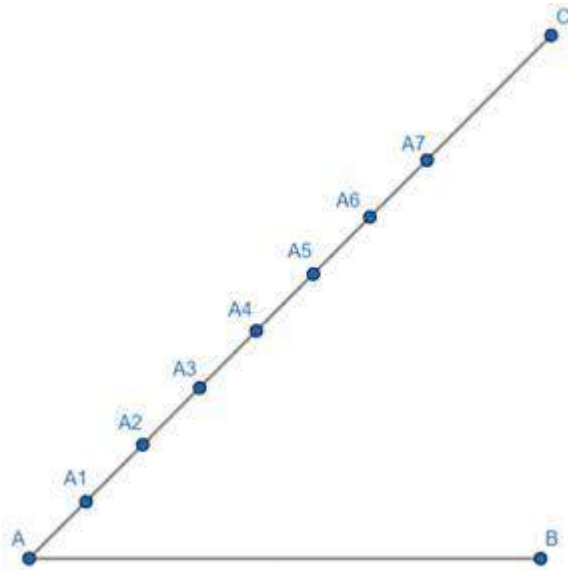

Step 3: We join points  $A_7$  and B.

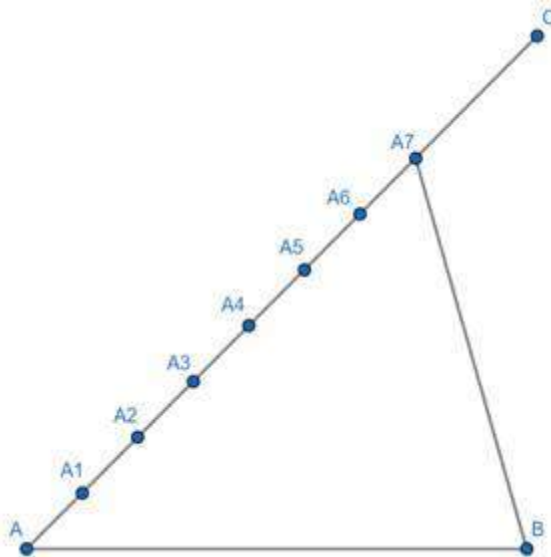

Step 4: We draw line segment  $A_4P$  such that  $A_4P \parallel A_7B$  and P is the point of intersection of this line segment with AB.

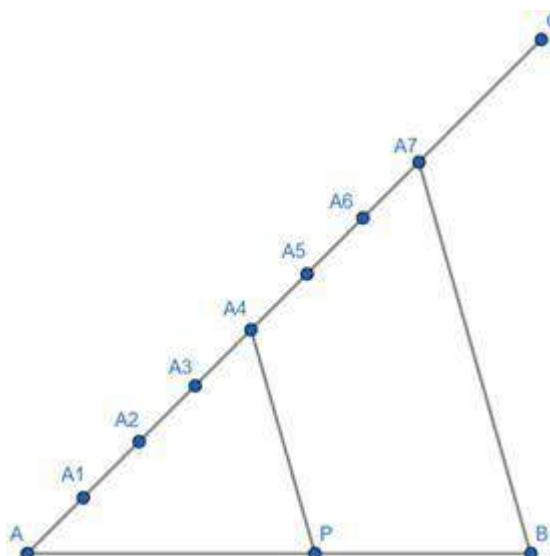

Point P divides AB in the ratio 4 : 3

25. **Solution:** Given:  $\sin A = \frac{1}{2}$  ... eq. 1

And we know that,  $\cot A = \frac{1}{\tan A} = \frac{\cos A}{\sin A}$  ...eq. 2

We need to find the value of  $\cos A$ .

$\cos A = \sqrt{1 - \sin^2 A}$  ...eq. 3

( $\because \sin^2 \theta + \cos^2 \theta = 1$ )

$\Rightarrow \cos^2 A = 1 - \sin^2 A$

$\Rightarrow \cos A = \sqrt{1 - \sin^2 A}$

Substituting eq. 1 in eq. 3, we get

$\cos A = \sqrt{1 - 1/4}$

$= \sqrt{\frac{3}{4}} = \frac{\sqrt{3}}{2}$

Substituting values of  $\sin A$  and  $\cos A$  in eq. 2, we get

$\cot A = \sqrt{3}/2 \times 2 = \sqrt{3}$

26. **Solution:** First two terms of an AP are  $a_1 = -3$  and  $a_2 = 4$ .

As we know,  $n$ th term of an AP is

$a_n = a + (n - 1)d$

where  $a$  = first term

$a_n$  is  $n$ th term

$d$  is the common difference

$a_2 = a + d$

$4 = -3 + d$

$d = 7$

Common difference,  $d = 7$   
 $a_{21} = a + 20d$   
 $= -3 + (20)(7)$   
 $= 137$

## Part- B

### 27. Solution:

Let  $\sqrt{3}$  be a rational number.

Then  $\sqrt{3} = p/q$  HCF  $(p,q) = 1$

Squaring both sides

$$(\sqrt{3})^2 = (p/q)^2$$

$$3 = p^2/q^2$$

$$3q^2 = p^2$$

3 divides  $p^2 \Rightarrow 3$  divides  $p$

3 is a factor of  $p$

Take  $p = 3c$

$$3q^2 = (3c)^2$$

$$3q^2 = 9c^2$$

3 divides  $q^2 \Rightarrow 3$  divides  $q$

3 is a factor of  $q$

Therefore 3 is a common factor of  $p$  and  $q$

It is a contradiction to our assumption that  $p/q$  is rational.

Hence  $\sqrt{3}$  is an irrational number.

### 28. Solution: (i) **Theorem:** The lengths of tangents drawn from an external point to a circle are equal.

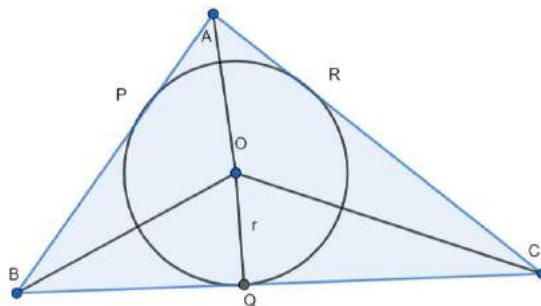

Therefore,

$$AP = AR$$

$$BP = BQ$$

$$CQ = CR$$

$$AB + CQ = AP + BP + CQ$$

$$AB + CQ = AR + BP + CR$$

$$AB + CQ = (AR + CR) + BP$$

$$AB + CQ = AC + CQ$$

**Hence, Proved.**

(ii) Joining OA, OB and OC, we get,

Area of  $\Delta ABC$  = Area of  $\Delta OBC$  + Area of  $\Delta OAB$  + Area of  $\Delta OAC$

$$= \frac{1}{2} (BC \times OQ) + \frac{1}{2} (AB \times OP) + \frac{1}{2} (AC \times OR)$$

$$= \frac{1}{2} (BC \times r) + \frac{1}{2} (AB \times r) + \frac{1}{2} (AC \times r)$$

$$= \frac{1}{2} (AB + BC + AC) \times r$$

$$\text{Area of } \Delta ABC = \frac{1}{2} (\text{Perimeter of } \Delta ABC) \times r$$

**Hence, Proved.**

29. **Solution:** Let the present age of Anjali be  $x$  and of Dimple be  $y$ .

Five years hence,

$$\text{Age of Anjali} = (x + 5) \text{ years}$$

$$\text{Age of Dimple} = (y + 5) \text{ years}$$

$$\text{Age of Anjali} = 3(\text{Age of Dimple})$$

$$x + 5 = 3(y + 5)$$

$$x + 5 = 3y + 15$$

$$x - 3y = 10 \dots\dots(1)$$

Five years ago,

$$\text{Age of Anjali} = (x - 5)$$

$$\text{Age of Dimple} = (y - 5)$$

$$\text{Age of Anjali} = 7(\text{Age of Dimple})$$

$$x - 5 = 7(y - 5)$$

$$x - 5 = 7y - 35$$

$$x - 7y = -30 \dots\dots(2)$$

Subtracting equation 2 from equation 1, we get,

$$(x - 3y) - (x - 7y) = 10 - (-30)$$

$$x - 3y - x + 7y = 10 + 30$$

$$4y = 40$$

$$y = 10 \text{ years}$$

Putting the value of 'y' in equation 1, we get,

$$x - 3 \times 10 = 10$$

$$x - 30 = 10$$

$$x = 40 \text{ years}$$

Hence, the age of Anjali is 40 years and age of Dimple is 10 years.

30. **Solution:** Let the number of red balls be  $x$ . And the number of white balls be  $y$ .

Then, number of blue balls =  $2y$

Now,

$$\text{Total number of balls} = (x + y + 2y) = (x + 3y)$$

$$\text{Probability of drawing a red ball} = \frac{\text{Number of red balls}}{\text{Total balls}}$$

Therefore,





$$\frac{x}{x + 3y} = \frac{1}{2}$$

$$2x = x + 3y$$

$$x = 3y \dots (1)$$

$$\text{Now, total balls} = x + x = 2x$$

$$\text{Number of white balls} = y$$

$$\text{And from equation 1, } y = \frac{x}{3}$$

$$\text{The probability of drawing a white ball} = \frac{\text{Number of white balls}}{\text{Total balls}}$$

$$P(\text{white ball}) = \frac{\frac{x}{3}}{2x}$$

$$= \frac{1}{6}$$

Hence, the probability of drawing a white ball is  $\frac{1}{6}$ .

**OR**

There is a total of 52 cards in a pack of cards.

Now, all queens, aces and kings are removed.

$$\text{Therefore, total cards left} = 52 - 12 = 40$$

In which,

$$\text{Number of red cards} = 20$$

$$\text{Number of black cards} = 20$$

$$(i) P(\text{black card}) = \frac{\text{Number of black cards}}{\text{Total cards}}$$

$$P(\text{black card}) = \frac{20}{40} = \frac{1}{2}$$

$$(ii) P(\text{red card}) = \frac{\text{Number of red cards}}{\text{Total cards}}$$

$$P(\text{red cards}) = \frac{20}{40} = \frac{1}{2}$$

(iii) In face cards, only jacks are left. And out of them there are two red jack cards.

Therefore,

$$P(\text{red face card}) = \frac{\text{Number of red face cards}}{\text{Total cards}} = \frac{2}{40} = \frac{1}{20}$$

31. **Solution: Given:**

$$\text{The radius of cylinder} = \text{radius of hemisphere} = \frac{7}{2} \text{ cm}$$

Diagram is given below:

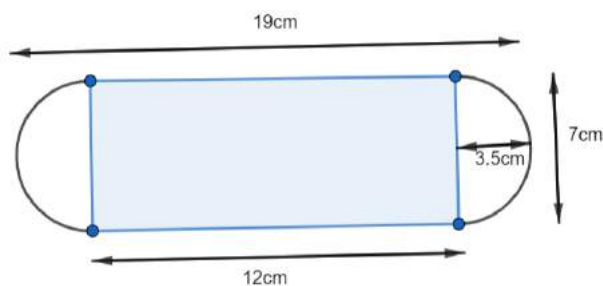

$$\text{The height of cylinder} = \left(19 - 2 \times \frac{7}{2}\right)$$

$$= 19 - 7$$

$$= 12 \text{ cm}$$

So,

$$\text{Volume of the cylinder} = \pi r^2 h$$

$$= \pi \times (3.5)^2 \times 12$$

$$= 147\pi \text{ cm}^3$$

$$\text{Volume of 2 hemispheres} = 2 \times \frac{2}{3} \pi r^3$$

$$= 2 \times \frac{2}{3} \times \pi \times (3.5)^3$$

$$= 57.16\pi \text{ cm}^3$$

The volume of the solid = Volume of the cylinder + Volume of a hemisphere

$$= 147\pi + 57.16\pi$$

$$= 204.16\pi$$

$$= \frac{204.16 \times 22}{7}$$

$$= \frac{4491.52}{7}$$

$$= 641.64 \text{ cm}^3$$

The surface area of the solid = CSA of cylinder + Surface area of 2 hemisphere

$$= 2\pi r h + 2 \times 2\pi r^2$$

$$= 2\pi r(h + 2r)$$

$$= 2 \times \frac{22}{7} \times 3.5(12 + 2 \times 3.5)$$

$$= 2 \times \frac{22}{7} \times 3.5(12 + 7)$$

$$= 2 \times \frac{22}{7} \times 3.5(19)$$

$$= 418 \text{ cm}^2$$

32. **Solution:** L.H.S =  $\frac{\tan x + \sec x - 1}{\tan x - \sec x + 1}$

We know that:  $\sec^2 x - \tan^2 x = 1$ .

$$\begin{aligned} \text{Therefore, L.H.S} &= \frac{(\tan x + \sec x) - (\sec^2 x - \tan^2 x)}{\tan x - \sec x + 1} \\ [\text{Since, } (a^2 - b^2) &= (a + b)(a - b)] \\ &= \frac{(\tan x + \sec x) - (\sec x + \tan x)(\sec x - \tan x)}{\tan x - \sec x + 1} \\ &= \frac{(\tan x + \sec x)(1 - \sec x + \tan x)}{\tan x - \sec x + 1} \\ &= \tan x + \sec x = \frac{\sin x}{\cos x} + \frac{1}{\cos x} = \frac{1 + \sin x}{\cos x} \\ &= \text{R.H.S} \end{aligned}$$

**Hence, Proved.**

33. **Solution:** Given: radius of the quadrant = 28cm

This will be the diagonal of the square.

Let the side of the square = a cm

By Pythagoras theorem,

$$a^2 + a^2 = 28^2$$

$$2a^2 = 784$$

$$a^2 = 392 \text{ cm}^2$$

We know that, Area of square = (side)<sup>2</sup> = a<sup>2</sup>

Therefore, Area of square = 392 cm<sup>2</sup>

Now, Area of a quadrant of a circle =  $\frac{1}{4} \pi r^2$

Putting r = 28cm, we get

$$\text{Area of a quadrant of a circle} = \frac{1}{4} \times \frac{22}{7} \times 28 \times 28$$

$$\text{Area of a quadrant of a circle} = (22 \times 28) \text{ cm}^2$$

$$\text{Area of a quadrant of a circle} = 616 \text{ cm}^2$$

Area of shaded region = Area of a quadrant of the circle – Area of square

$$\text{Area of shaded region} = (616 - 392) \text{ cm}^2$$

Hence, the area of the shaded region is 224 cm<sup>2</sup>

**OR**

Given: Length of the minute hand = 10cm

First, we need to calculate the angle swept by the minute hand from 6:10 to 7:05

In 60 minutes, minute hand sweep  $360^\circ$ .

Therefore, in 1 minute it will sweep  $= \frac{360^\circ}{60} = 6^\circ$

Difference in minutes from 6:10 to 7:05 = 55 minutes

The angle swept by the minute hand =  $55 \times 6^\circ$

Therefore, the angle swept by minute hand =  $330^\circ$

We know that area of sector =  $\frac{\theta}{360^\circ} \times \pi \times r^2$

Here,  $\theta = 330^\circ$  and  $r = 10\text{cm}$

Therefore,

Area swept by minute hand =  $\left(\frac{330}{360}\right)^\circ \times \frac{22}{7} \times 10^2$

Area swept by minute hand =  $\frac{11}{12} \times \frac{22}{7} \times 100$

Area swept by minute hand =  $288.1 \text{ cm}^2$

## PART – B

34. **Solution:**

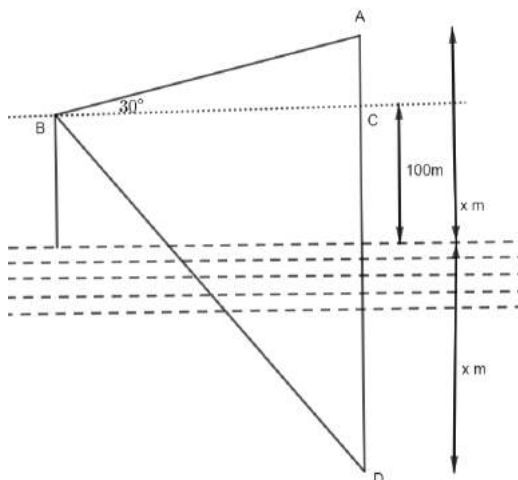

A is the helicopter and D is its reflection in the lake.

Let the height of the helicopter be  $x$ . and  $BC = y$ .

In  $\triangle ABC$ ,

$$\tan 30^\circ = \frac{AC}{BC}$$

$$\frac{1}{\sqrt{3}} = \frac{x - 100}{y}$$

$$y = \sqrt{3}(x - 100)\text{m} \dots (1)$$

In  $\triangle BCD$ ,

$$\tan 45^\circ = \frac{CD}{BC}$$

$$1 = \frac{x + 100}{y}$$

$$y = (x + 100)m \dots (2)$$

From equations 1 and 2,

$$x + 100 = \sqrt{3}(x - 100)$$

$$x + 100 = \sqrt{3}x - 100\sqrt{3}$$

$$\sqrt{3}x - x = 100 + 100\sqrt{3}$$

$$x(\sqrt{3} - 1) = 100(1 + \sqrt{3})$$

$$x = \frac{100(\sqrt{3} + 1)}{\sqrt{3} - 1}$$

Rationalizing the fraction, we get

$$x = \frac{100(\sqrt{3} + 1)^2}{2} m$$

$$x = 50(4 + \sqrt{3})m$$

**OR**

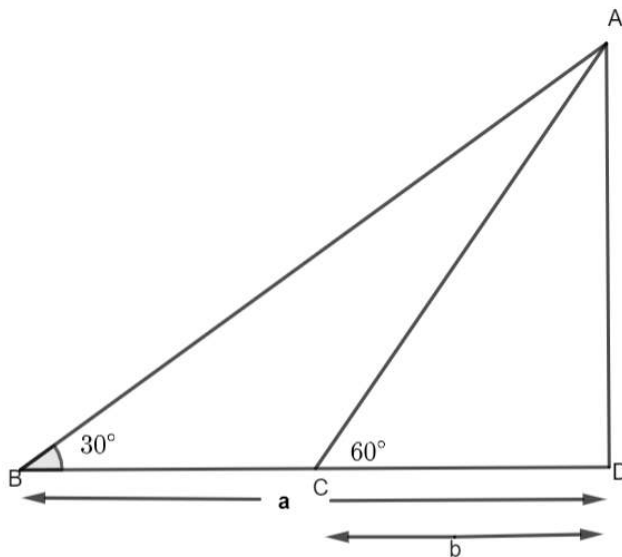

Let the height of the tower,  $AD = h$  m

Now, in  $\triangle ADC$ , we have,

$$\tan 60^\circ = \frac{AD}{CD}$$

$$\sqrt{3} = \frac{h}{b}$$

$$h = b\sqrt{3}m$$

$$b = \frac{h}{\sqrt{3}} \dots (1)$$

Similarly, in  $\triangle ADB$ , we have,

$$\tan 30^\circ = \frac{AD}{BD}$$

$$\frac{1}{\sqrt{3}} = \frac{h}{a-b}$$

$$h\sqrt{3} = a - b$$

Putting the value of b from equation 1, we get,

$$h\sqrt{3} = a - \frac{h}{\sqrt{3}}$$

$$h\sqrt{3} + \frac{h}{\sqrt{3}} = a$$

$$\left(\frac{4h}{\sqrt{3}}\right) = a$$

$$h = \frac{\sqrt{3}a}{4} \text{m.....(2)}$$

From (1) and (2)

$$\frac{\sqrt{3}a}{4} = \sqrt{3}b$$

$$\frac{a}{b} = 4$$

$$\sqrt{\frac{a}{b}} = 2$$

Hence, the value of  $\sqrt{\frac{a}{b}}$  is 4.

### 35. **Solution:**

**Given:**  $a_p = q$  and  $a_q = p$

**To Prove:**  $a_n = p + q - n$

We know that,

$$a_n = a + (n - 1)d$$

Where, a = first term, d = common difference and n = number of terms.

Therefore,

$$p\text{th term} = a_p$$

$$a_p = a + (p - 1)d = q \text{.....(1)}$$

$$q\text{th term} = a_q$$

$$a_q = a + (q - 1)d = p \text{....(2)}$$

Subtracting equation 2 from equation 1, we get,

$$(p - 1)d - (q - 1)d = q - p$$

$$pd - d - qd + d = q - p$$

$$(p - q)d = (q - p)$$

$$d = -\frac{p - q}{p - q}$$

$$d = -1$$

Putting the value of 'd' in equation (1), we get

$$a + (p - 1)(-1) = q$$

$$a - p + 1 = q$$

$$a = p + q - 1$$

Now, putting the values of 'a' and 'd' in the formula for nth term, we get,

$$a_n = (p + q - 1) + (n - 1)(-1)$$

$$a_n = p + q - 1 - n + 1$$

$$\mathbf{a_n = p + q - n}$$

**Hence, Proved.**

36. **Solution: Given:** Mean of the data is 14

**Concept Used:**

$$\text{Mean} = \frac{\sum fx}{\sum f}$$

<b>x</b>	<b>f</b>	<b>fx</b>
5	10	50
10	20	200
12	15	180
P	20	20p
16	12	192
18	8	144
20	4	80
	N = 89	$\sum fx = 20p + 846$

Given, mean = 14

$$\frac{\sum fx}{\sum f} = 14$$

$$\frac{20p + 846}{89} = 14$$

$$20p = 1246 - 846$$

$$20p = 400$$

$$p = \frac{400}{20}$$

$$p = 20$$

**Hence, the value of p is 20.**